



GOETZE[®]

G-6007 INDUSTRIAL SPARK PLUG

The massive quad electrode design has been developed to achieve extreme lifetime in open chamber applications. With a shorter projection (compared to comparable long life spark plugs) of the spark plug into the combustion chamber, the spark plug is specialized for different applications where long service intervals with perfect overall lifetimes and re-gapping capabilities are required.

With its HEX size of 21mm the spark plug fits well into cylinder heads with limited clearance around the spark plug to the cylinder head bore. Ideal for engines, fueled by Natural Gas and Biogas, where the end user is looking for a suitable and capable OE replacement spare part.

G-6007

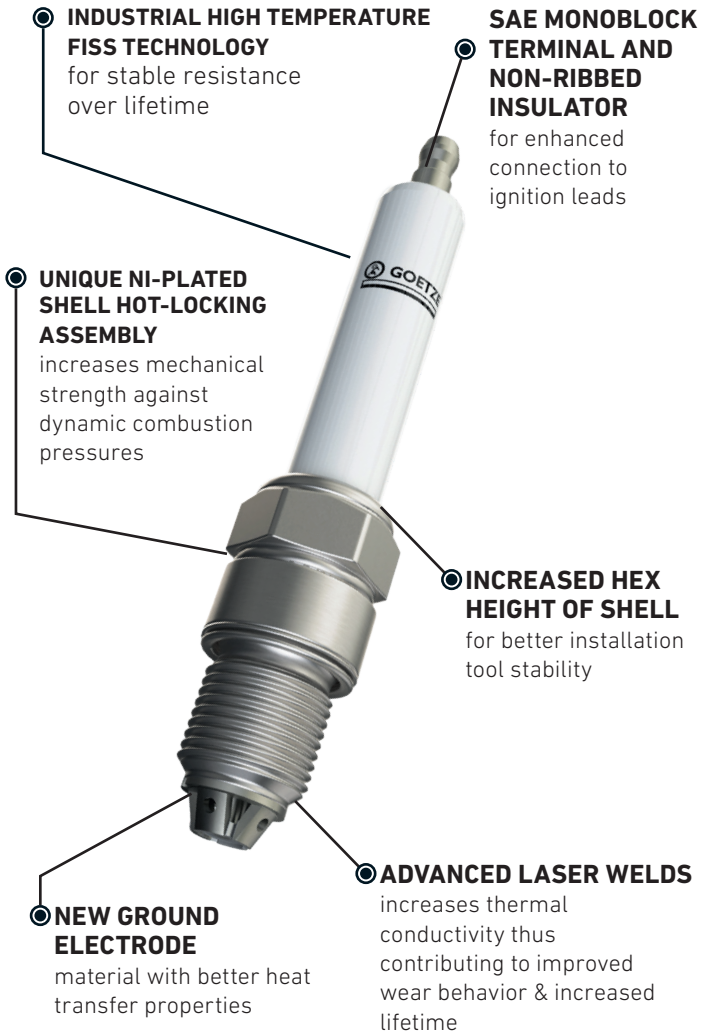

Lifetime*

10.000 h
25.000 h

Electrode Gap, Nom.

0.2 mm
0.3 mm
0.5 mm

Electrode Resistance

2 kΩ
3 - 12 kΩ
16 kΩ

* Lifetime depends on operating conditions including, but not limited to: fuel, duty cycle/load, ignition system, and environmental conditions.

Federal-Mogul Ignition GmbH
 Bürgermeister-Schmidt-Str. 17
 51399 Burscheid, Germany
<http://www.ignition.tenneco.com>

© 2022 Tenneco Inc. All rights reserved. All trademarks are owned by Tenneco Inc. or one of its subsidiaries, in one or more countries. G-6007 Rev.02/2022

Basic Technical Data

Properties	G-6007
Suppressor Resistor	3 - 12 kΩ
Hex	20.8 mm
Thread	M18 x 1.5
Thread length	20.05 mm
Precious metals	Iridium/Platinum
Electrode gap	nom. 0.3
Tightening Torque (Cast iron)	50-60 Nm (37-44 lbf ft) w/o lubricant
Lifetime*	~10,000 hours

Dimensions

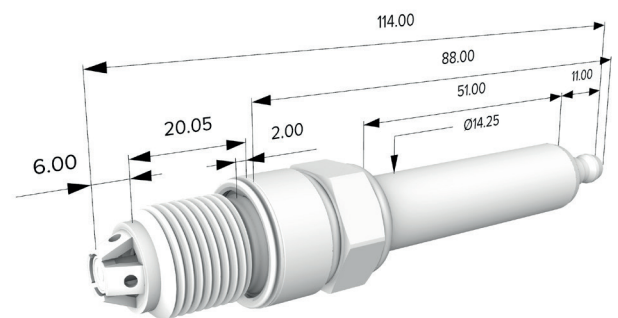

Target Applications

- Industrial stationary engines
- Power generation/CHP
- Open chamber combustion engines
- Natural Gas
- Biogas

Engines

- INNIO Jenbacher type 2 and 3
- MAN E28
- Cummins QSV

Cross References

INNIO:

- 314322; 340051; 1233804; 1233808; 190441

Federal-Mogul:

- 18GZ44 - Z283
- FB78WPN