



## C-4001 **CHAMPION INDUSTRIAL SPARK PLUG**

This plug is a newly designed High-Performance spark plug. The improved ceramic material allows high voltage strength for future application.

Tenneco's new M14 J-Gap series with Double Iridium electrodes starts with new nomenclature. C-4001 stands for double Iridium M14 J-Gap high performance spark plugs developed for usage in natural gas engines in stationary and transit applications.





# C-4001

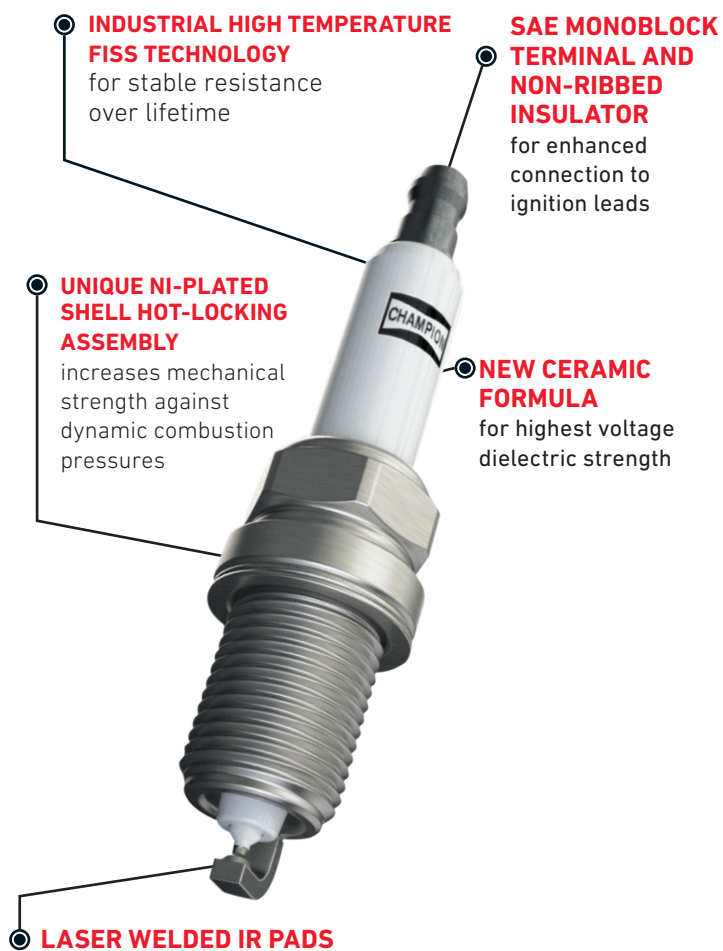

## Basic Technical Data

Properties	C-4001
Suppressor Resistor	3 - 12 kΩ
Hex	16mm
Thread	M14x1,25
Thread length	19mm
Precious metals	Iridium/Iridium
Electrode gap	nom. 0.4mm
Tightening Torque (Cast iron)	30-40Nm

## Dimensions

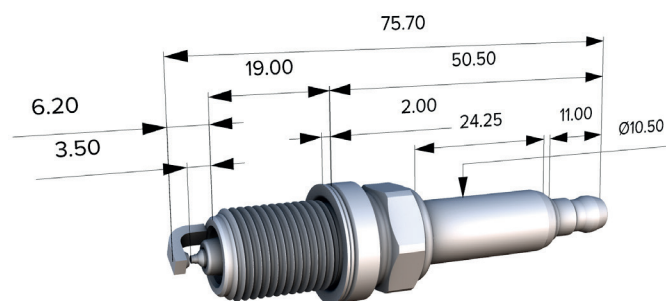

## Electrode Gap, Nom.



## Electrode Resistance



## Target Applications

- Commercial Truck Off-Highway (Trucks, Buses, Construction machines)

## Engines

- Scania, Daimler, MAN, Iveco

## Cross References

- BOSCH WR3KI332

Federal-Mogul Ignition GmbH  
Bürgermeister-Schmidt-Str. 17  
51399 Burscheid, Germany  
<https://ignition.tenneco.com>

© 2020 Tenneco Inc. All rights reserved. All trademarks are owned by Tenneco Inc. or one of its subsidiaries, in one or more countries. C-4001 Rev 11/2021